

# **Municipality of Anchorage**

**Port of Alaska**

## **ENVIRONMENTAL SITE ASSESSMENT SERVICES REQUEST FOR PROPOSAL NO. 2022P034**

### **ATTACHMENT 08**

#### **Prescriptive Information - Terminal 1 (T1) and Terminal 2 (T2) - Rev. 01**

# Port of Alaska Modernization Program Prescriptive Information Terminal 1 and Terminal 2



*Prepared for*

Municipality of Anchorage/Port of Alaska



2000 Anchorage Port Road  
Anchorage, Alaska 99501

Rev. 01

February 5, 2019



CH2M HILL Engineers, Inc.  
Anchorage, Alaska

# Revisions

Revisions					
Rev	Description	Date	Prepared	Checked	Approved
0	Original Document	May 11, 2017	DP	GN	JB
1	Updated after completion of the PCT design	02/05/2019	DP	GJN	

# Contents

Section	Page
<b>Revisions .....</b>	<b>iii</b>
<b>Acronyms and Abbreviations .....</b>	<b>vii</b>
<b>1 Introduction .....</b>	<b>1-1</b>
<b>2 Civil Site Development, Grading, Drainage, Utilities, and Traffic Control .....</b>	<b>2-1</b>
2.1 Codes, Standards, and References .....	2-1
2.2 Arctic Engineering Principles .....	2-2
2.3 Design Criteria.....	2-2
2.3.1 Stormwater Pollution and Prevention .....	2-2
2.3.2 Site Grading.....	2-2
2.3.3 Utilities .....	2-3
2.3.4 Site Access, Circulation, and Parking .....	2-4
2.3.5 Paving.....	2-4
<b>3 Marine Structures.....</b>	<b>3-1</b>
3.1 Codes, Standards, and References .....	3-1
3.2 Design Criteria.....	3-1
3.2.1 Service Life .....	3-1
3.2.2 Berthing Loads .....	3-2
3.2.3 Mooring Loads .....	3-2
3.2.4 Thermal Loads.....	3-2
3.2.5 Ice Loads .....	3-2
3.2.6 T1 and T2 Design Live Loads .....	3-2
3.2.7 T1 Specific Design Live Loads.....	3-3
3.2.8 T1 Seismic Performance Requirements.....	3-4
3.2.9 T2 Specific Design Live Loads.....	3-4
3.2.10 T2 Seismic Performance Requirements.....	3-6
<b>4 Rail-mounted, Container-handling Gantry Crane .....</b>	<b>4-1</b>
4.1 Codes, Standards, and References .....	4-1
4.2 Design Criteria.....	4-1
<b>5 Electrical System.....</b>	<b>5-1</b>
5.1 Codes, Standards, and References .....	5-1
5.2 Design Criteria.....	5-1
5.2.1 General Power Requirements.....	5-1
5.2.2 Area Lighting .....	5-2
<b>Tables</b>	
3-1 Berthing Loads .....	3-2
3-2 T1 Seismic Design Performance.....	3-4
3-3 T2 Seismic Design Performance.....	3-6
4-1 Geometry Criteria .....	4-1
4-2 Weight and Load Criteria .....	4-2

# Acronyms and Abbreviations

°	degree
AASHTO	American Association of State Highway and Transportation Officials
ACS	Alaska Communications System
ADA	Americans with Disabilities Act of 1990
ADOT&PF	State of Alaska Department of Transportation and Public Facilities
APDES	Alaska Pollutant Discharge Elimination System
PAMP	Port of Alaska Modernization Program
ASCE	American Society of Civil Engineers
ATMS	Alaska Traffic Manual Supplement
AWWU	Anchorage Water and Wastewater Utility
BICSI	Building Industry Consulting Service International
CLE	Contingency Level Earthquake
container cranes	rail-mounted, container-handling gantry crane
COPRI	Coastal, Oceans, Ports, and Rivers Institute
DE	Design Earthquake
T1	Terminal 1
T2	Terminal 2
DOD	U.S. Department of Defense
DOR	Designer of Record
F	Fahrenheit
ft	foot
GCI	General Communications Inc.
HDPE	high-density polyethylene
IEEE	Institute of Electrical and Electronics Engineers
IESNA	Illuminating Engineering Society of North America
LT	long ton
m/s	meter per second
MASS	Municipality of Anchorage Standard Specifications
MCE	maximum considered earthquake
ML&P	Anchorage Municipal Light and Power
MOA	Municipality of Anchorage
mph	mile per hour
MS4	Municipal Separate Storm Sewer System

ACRONYMS AND ABBREVIATIONS

MUTCD	Manual on Uniform Traffic Control Devices
NEMA	National Electrical Manufacturers Association
NFPA	National Fire Protection Association
OLE	Operational Level Earthquake
PCC	portland cement concrete
POA	Port of Alaska
psi	pounds per square inch
PVC	polyvinyl chloride
U.S.	United States
XHHW	XLPE, high-heat-resistant, water-resistant
XLPE	cross-linked polyethylene

# Introduction

The Port of Alaska (POA) is in the process of modernizing its facilities through implementation of the Port of Alaska Modernization Program (PAMP). The intent of the program is to provide a port facility that will efficiently meet demands for delivery of food, fuel, cement, and other commodities to Anchorage and the rest of Alaska over the next 75 years.

This report contains a list of the relevant design codes and standards, along with the performance criteria for further development of Terminals 1 and 2 (T1 and T2). This document is intended to be multidisciplinary, covering the disciplines necessary to complete the design of new T1 and T2.

Because this is a multiyear program, code and standard version dates are purposely not shown, as they may change from year to year. It will be the Designer of Record's (DOR's) responsibility at the time of design to verify and use the most current versions. It will also be the DOR's responsibility to bring to the attention of the owner additional design codes and standards that are applicable to the work.

The DOR is advised that the POA is a secure facility in immediate proximity to a United States (U.S.) military installation and airfield.

# Civil Site Development, Grading, Drainage, Utilities, and Traffic Control

Site development (including stormwater pollution and prevention and drainage), grading, utilities, traffic control measures, and paving shall be designed in accordance with the codes and standards governing site development in the MOA and State of Alaska requirements at the time of detailed design. These standards shall be determined by the civil DOR during the design process and shall be incorporated into the contract documents. The DOR should be aware that the POA has an existing Alaska Pollutant Discharge Elimination System (APDES) MS4 permit number AKS052426 which is effective through July 31, 2020.

## 2.1 Codes, Standards, and References

The following are representative of the codes and standards that shall be incorporated into the contract documents as applicable:

- MOA Design Standards:
  - MOA Design Criteria Manual
  - Municipality of Anchorage Standard Specifications (MASS)
  - MOA Drainage Design Guidelines
  - MOA Low Impact Development Design Guidance Manual
  - National Pollutant Discharge Elimination System - Municipal Separate Storm Sewer System (MS4) Permit 2010
  - Anchorage Water and Wastewater Utility (AWWU) Design and Construction Practices Manual
- State of Alaska Design Standards and Programs:
  - Alaska Traffic Manual Supplement (ATMS)
  - Alaska Sign Design Specifications
  - Alaska Pollutant Discharge Elimination System (APDES) Program
  - State of Alaska Department of Transportation and Public Facilities (ADOT&PF) Alaska Flexible Pavement Design Manual
- Federal Design Standards and Policies:
  - A Policy on Geometric Design of Highways and Streets (American Association of State Highway and Transportation Officials [AASHTO])
  - AASHTO Pavement Design Method
  - Americans with Disabilities Act of 1990 (ADA) - Accessibility Guidelines (U.S. Architecture and Transportation Barriers Compliance Board)
  - Manual on Uniform Traffic Control Devices (MUTCD)
  - Asphalt Institute MS-4: The Asphalt Handbook
  - Asphalt Institute MS-23: Thickness Design - Asphalt Pavement for Heavy Wheel Lands



- U.S. Department of Defense (DOD) Unified Facilities Criteria
- National Fire Protection Association (NFPA) 24, Standard for the Installation of Private Fire Service Mains and Their Appurtenances
- NFPA 307, Standard for the Construction and Fire Protection of Marine Terminals, Piers, and Wharves

## 2.2 Arctic Engineering Principles

Conditions at the Port can be generally characterized as subarctic; thus, civil design shall incorporate sound engineering principles to address these conditions. Examples of sound practices that shall be considered and incorporated as necessary by the DOR include the following:

- Eliminating the potential for differential frost heave under paved areas and walkways by excavating frost-susceptible soils and replacing them with nonfrost-susceptible soils
- Providing ample areas for snow removal and storage
- Insulating shallow bury (if required) sewer or water lines to prevent freezing
- Oversizing culverts, and providing thaw pipes to prevent ice damming and glaciation

## 2.3 Design Criteria

### 2.3.1 Stormwater Pollution and Prevention

Storm water pollution and prevention design criteria are contained in the MOA Drainage Design Guidelines. In addition to the MOA requirements, the State of Alaska administers the APDES, which contains specifics regarding construction discharge and site development, including requirements set forth in an MS4 permit. As noted above, the Port of Alaska has its own MS4 permit. The State criteria apply in addition to the MOA Guidelines, where the State requirements impose stricter criteria. The DOR shall determine the applicability of each design guide, including the applicability of the MS4 permit requirements, based on the project design specifics.

In general, storm water management is required for all site civil developments to avoid adverse impacts to properties due to increases in storm water runoff from land development and increases in storm water pollutant loading.

Designs shall provide erosion control facilities that will minimize the production of sediment due to soil erosion and that will control it from entering waterways offsite. Where applicable, combine requirements for erosion control with those for permanent storm water management to minimize construction disturbance.

Where groundwater conditions require excavation dewatering, discharge to a temporary pond in order to capture sediment prior to release to downstream natural waterways and existing storm sewers. Provide proper storm water runoff collection and control for these areas. Consider environmental risks and requirements as required by regulations, and develop containment or treatment facilities as required. Oil/water separators may be needed for storm water discharge.

### 2.3.2 Site Grading

Site grading criteria will be taken from the references provided herein. Additionally, this section provides key aspects of the grading design.

The finished grading shall provide positive drainage away from buildings, structures, slabs, and other critical areas where the accumulation of water is not desirable. Graded areas should drain to streets, ditches, swales, or catch basins connected to the storm sewer system or other drainage feature.

Finished grade contours shall be shown on the plans at 1-foot intervals, and used to show the general shape of landforms and direction of slope for drainage. Contours shown at tighter intervals may be required at critical areas, such as pavements or sidewalks adjacent to buildings and structures.

Set the finished grades along the perimeter of buildings, slabs, and other structures to be 6 inches below the finished floor or slab elevation. Grade away from these facilities a distance of at least 10 feet at a recommended minimum slope of 5 percent to achieve positive drainage.

The DOR shall consider winter snow maintenance and plowing activities in the layout of sites. Ample space shall be provided for plowing snow, and snow storage areas shall be graded to drain during spring break-up.

Parking lots and large, open, paved areas shall be sloped to drain toward curbs and gutters at the sides or toward area drains or other drainage features in the middle of the pavement. Generally, to maintain good drainage characteristics, provide minimum slopes of 2 percent for paved areas and 3 percent for nonpaved areas. For drainage swales formed at the intersection of flat areas and pavement, a minimum slope of 1 percent shall be used.

The slopes of pavement surfaces draining towards gutters or swales shall be at 2 percent minimum. If required, a minimum slope of 1.5 percent on asphalt concrete and 1 percent on portland cement concrete (PCC) can be used on short drainage reaches of less than 25 feet. To account for winter icing, pavement slopes shall be as flat as possible while still providing positive site drainage. The maximum slopes on pavement surfaces shall be 5 percent. Accessible parking spaces and access aisles shall have surface slopes not exceeding 2 percent in all directions.

In addition, all site grading and drainage work shall comply with the Anchorage Municipal Code 23.105 “Grading, Fill, Excavation and Landscaping 2012 Edition” as adopted by the MOA Assembly on February 23, 2016.

### 2.3.3 Utilities

Utility design criteria will be taken from the references provided herein. Additionally, this section provides key aspects of utility design.

The POA is an industrial facility that contains infrastructure critical to state and municipal commerce and national defense. Unplanned interruptions to utility services can have significant consequences; however, these consequences can be mitigated by identifying utility conflicts early in the design process. Utility locating and coordination shall begin as early as possible during the schematic design phase of projects. The level of effort for each project will be dependent on the location and size of the new facility. Each design project shall develop a plan that describes the approach for utility locating during the design phase. The utility locating approach shall provide sufficient time to:

- Obtain maps of utilities
- Perform field identification and verification
- Allow utility companies to provide field markings
- Survey utilities
- Perform other related tasks as required

The DOR shall make every effort to identify and plan for utility conflicts during the design process and shall incorporate language into the contract documents that requires the contractor to further discover potential conflicts in the field prior to beginning construction.

Utilities at the POA are owned, operated, and maintained by a combination of public and private utility companies. Each utility has specific criteria and coordination requirements for new services, crossings,

or required relocations. Utility contacts can be obtained from the MOA utilities website at <http://www.muni.org/Residents/Pages/Utilities.aspx>. Specific information is included as follows:

- Sanitary Sewer and Water:
  - AWWU
- Electric:
  - Municipal Light and Power
- Natural Gas:
  - ENSTAR Natural Gas Company
- Telephone and Communication Systems:
  - Alaska Communications Systems
  - General Communication Incorporated

### 2.3.4 Site Access, Circulation, and Parking

Site access, circulation, and parking design criteria will be taken from the references provided herein. Additionally, this section provides the key aspects of their design.

The POA is a secure facility, and site access is commonly restricted or limited for security reasons. Corresponding to container vessel calls, Tuesdays and Sundays are normally the days with the highest traffic volume at the Port. Traffic movements and patterns associated with cargo loading and offloading activities are given priority. The DOR will need to determine how access to the project site is accommodated by the existing roadway system and shall coordinate haul routes, construction access, and final site access with POA security. Restrictions on access during construction shall be incorporated into the project bid documents, and prospective contractors shall be made aware of any restrictions that apply during the project bidding phase.

Small access roadways and driveways may be required to provide access from the existing roadways to the new facilities. For automobile and light truck parking areas, provide free traffic movement for smaller vehicles; however, allow for access by emergency and fire protection vehicles to buildings and other structures. The DOR is responsible for determining the fire marshal access requirements for fire protection equipment.

Parking requirements for employees, visitors, and operations and maintenance vehicles must be determined for each facility. Parking details are contained in the MOA's Code of Ordinances under Title 21. This code ensures that sites are developed to provide sufficient parking for the sites' various users. The number and size of required spaces is determined by these local regulations.

Provisions are required to accommodate persons with disabilities in accordance with the ADA. For parking areas of 100 parking spaces or less, a minimum of 4 percent of the spaces will be available for and restricted to accessible parking, with a fraction being rounded up to a whole space. In addition, one in every eight accessible spaces, but not less than one, will be served by an access aisle that is 8 feet wide and that is designated "van accessible." Accessibility ramps and curb cuts, with maximum slopes of 8.33 percent, are required to allow access from parking areas to access routes leading to buildings and other facilities. Check ADA regulations for requirements for facilities with parking areas of more than 100 spaces.

### 2.3.5 Paving

Pavement design criteria shall follow the guidelines established by the documents listed herein. The pavement sections shown in the preliminary plans were used for preliminary cost estimating and are based on common pavement thickness currently in use on State owned commercial roads in the Anchorage bowl, using MOA pavement types. The DOR shall further refine and complete the pavement design based on terminal usage patterns of the terminal operators.

# Marine Structures

Marine structures shall be designed in accordance with the codes and standards described in this section. These standards shall be confirmed and supplemented by the DOR as necessary during the design process and shall be incorporated into the contract documents.

## 3.1 Codes, Standards, and References

The following are representative of the codes and standards that shall be incorporated into the contract documents as applicable:

- ASCE/COPRI 61-14 Seismic Design of Piers and Wharves, 2014
- California Building Code (CBC) Volume 2 Chapter 31F Marine Oil Terminal Engineering and Maintenance Standards (MOTEMS), 2013
- ASCE 7-10 Minimum Design Loads for Buildings and Other Structures, 2010
- AASHTO LRFD Bridge Design Specifications, 7<sup>th</sup> Edition (ASSHTO LRFD SPECS), 2014
- National Fire Protection Association (NFPA) 307 Standard for the Construction and Fire Protection of Marine Terminals, Piers, and Wharves, 2011
- American Concrete Institute (ACI) 318-11 Building Code Requirements for Structural Concrete, 2011
- American Institute of Steel Construction (AISC) Steel Construction Manual 14<sup>th</sup> Edition, 2011
- American Welding Society (AWS) D1.5 Bridge Welding Code 6<sup>th</sup> Edition, 2010
- AWS D1.1 Structural Welding Code – Steel, 22<sup>nd</sup> Edition, 2010
- 29 CFR 1917.111 - MAINTENANCE AND LOAD LIMITS
- Port of Alaska Modernization Program Seismic Design Manual, Municipality of Anchorage (MOA)/POA
- For Buildings and topside structures use IBC as adopted and amended by the MOA

## 3.2 Design Criteria

The following sections overview the expected service life, berthing loads, design live loads, and seismic performance requirements. The DOR shall refer to the APMP Seismic Design Manual for further development and details of the structural and seismic design criteria.

### 3.2.1 Service Life

- The platform and trestle components shall be designed for a minimum service life of 75 years
- The mooring dolphin at T2 shall be designed for a minimum service life of 50 years
- The fenders shall be designed for a minimum service life of 25 years

### 3.2.2 Berthing Loads

**Table 3-1. Berthing Loads**

*Port of Alaska Modernization Program*

Ship Characteristics	Container Vessel	Military Vessel (Large, medium speed, Ro-Ro)
Length Overall (LOA) (ft)	1000	950
Beam (ft)	140	106
Draft (ft)	45	36
Deadweight Tonnage (DWT)	76,000	62,000
Approach Speed Perpendicular to berth	0.46	0.50
Approach Angle (Degrees)	10	10

### 3.2.3 Mooring Loads

- Mooring bollard capacity = 200 metric tons

### 3.2.4 Thermal Loads

- For concrete superstructure:
  - Maximum Design Temperature = °80F
  - Minimum Design Temperature = -°30F
- For steel superstructure and steel/concrete composite superstructure
  - Maximum Design Temperature = °90F
  - Minimum Design Temperature = -°35F

### 3.2.5 Ice Loads

- Maximum horizontal ice loads are developed from the following ice characteristics. The Port of Alaska Modernization Program Seismic Design Manual provides additional design information regarding ice loading.
  - Maximum Design Ice floe size: 750 feet
  - Maximum Design Ice Thickness: 36 inches
  - Ice crushing strength = 300 psi
  - Ice flexural strength = 100 psi
- Vertical Ice Loads Due to Accretion
  - Max ice accretion on cylindrical piles = 3 feet radial growth

### 3.2.6 T1 and T2 Design Live Loads

- The uniform live load shall be 1000 psf
- Truck load loading shall accommodate AASHTO HS25

### 3.2.6.1 Loaded Container Handler (Based on Taylor TETCP 1100)

- IMPACT FACTOR = 10%

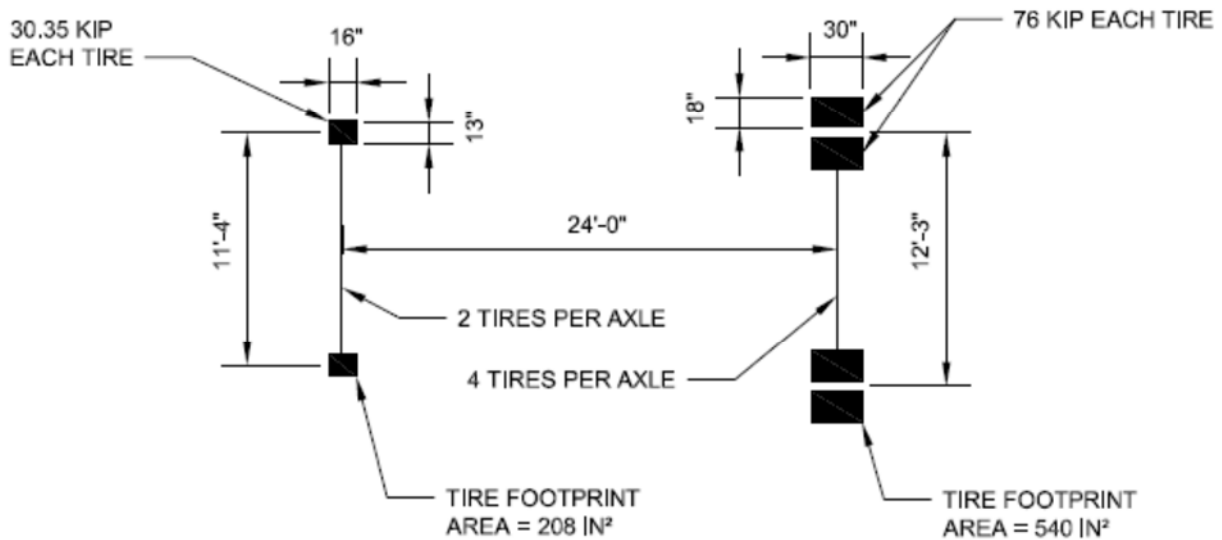

### 3.2.7 T1 Specific Design Live Loads

#### 3.2.7.1 Rail Mounted Gantry Crane

EQUIVALENT UNIFORM LOAD:

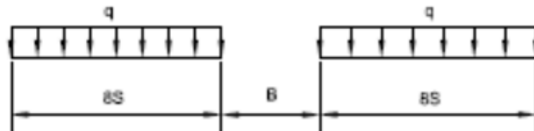

NOTE:

1.  $S = 4 \times 11''$   $B = 8 \times 6''$
2. FOR VALUES OF  $q$ , SEE TABLE BELOW.

		SERVICE LOAD $q$ (KLF)		STRENGTH LOAD $q$ (KLF)	
		LANDSIDE	WATERSIDE	LANDSIDE	WATERSIDE
WHARF OPERATING AREAS	VERTICAL	32	35	40	44
	LATERAL TO CRANE RAIL	1,8	1,8	2,2	2,2
CRANE STORAGE AREAS*	VERTICAL	43	39	64	59
	LATERAL TO CRANE RAIL	3,4	3,4	5,1	5,1

\* STOWED WIND, WITH STOW PINS AND TIE DOWNS ENGAGED.

WHEEL LOADS:

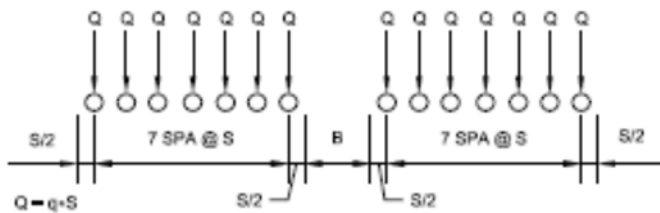

TIE DOWN LOADS:

- MAX. UPLIFT @ EACH CORNER = 485 KIP (SERVICE)/778 KIP (STRENGTH)

STOWAGE PIN LOADS:

- MAX. STOWAGE PIN LOADS @ EACH RAIL (LONGITUDINAL PARALLEL TO CRANE RAILS) = 280 KIP (SERVICE)/450 KIP (STRENGTH)

## 3.2.8 T1 Seismic Performance Requirements

**Table 3-2. T1 Seismic Design Performance**

*Port of Alaska Modernization Program*

Structure	Design Classification	Seismic Hazard Level	Seismic Performance Level
New T1 wharf approach trestles	Seismic Berth	OLE	Minimal damage
	Seismic Berth	CLE	Controlled and repairable damage
	Seismic Berth	DE	Life Safety Protection

Notes:

DE level is equivalent to two-thirds of MCE in accordance with ASCE 7-10. Ground motions from ASCE 7-10 exceed those from ASCE 7-05, *Minimum Design Loads for Buildings and Other Structures*, specified in ASCE/COPRI 61-14.

## 3.2.9 T2 Specific Design Live Loads

### 3.2.9.1 Roll on Roll off Ramp

AXLE LOADS:

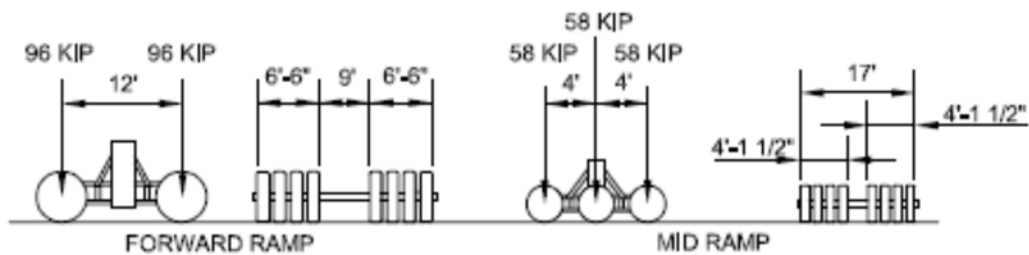

Note: This loading shall also be applied to the north most trestle of T1 to facilitate construction phasing

### 3.2.9.2 Mobile Cranes

- Impact factor for wheel loads & Tread load = 10%

**275 Ton capacity crawler crane (Based on Manitowoc 999)**

MAXIMUM UNIFORM GROUND PRESSURE:

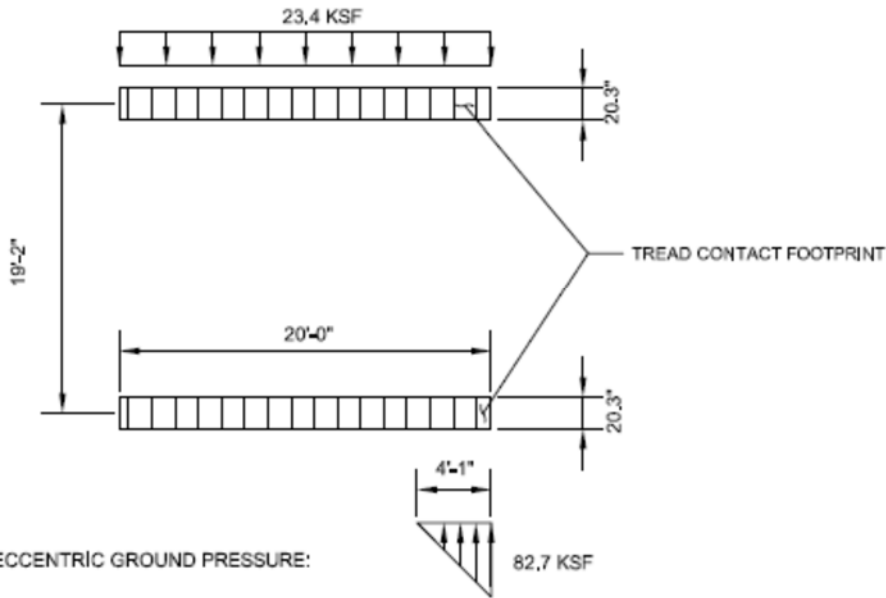

**275 Ton capacity truck crane (Based on Grove GMK7550)**

WHEEL LOADS:

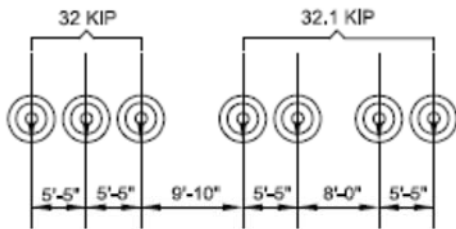

OUTRIGGER FLOAT LOADS:

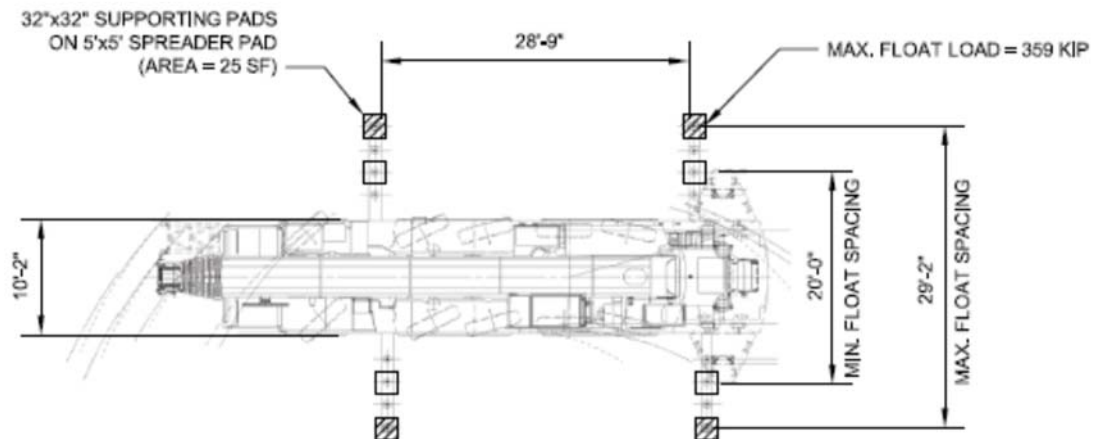



**Mobile Harbor Crane (Based on Liebherr LHM 550)**

WHEEL LOADS:

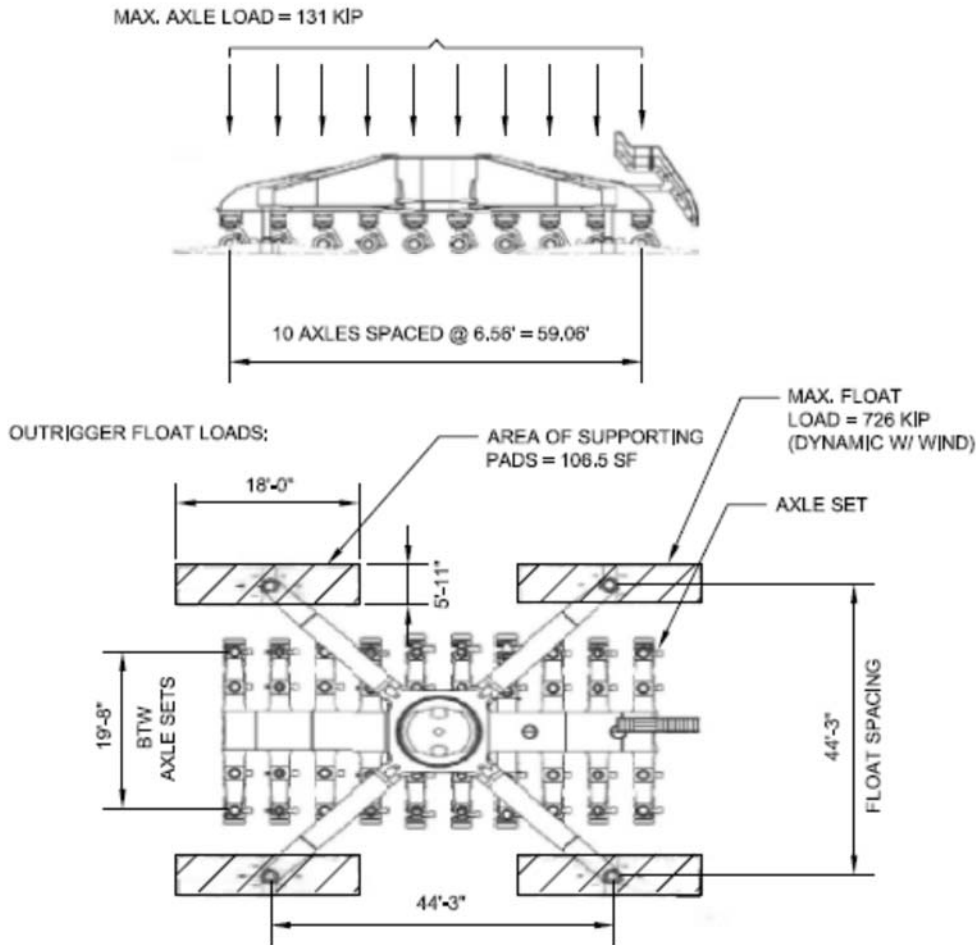
**3.2.10 T2 Seismic Performance Requirements****Table 3-3. T2 Seismic Design Performance***Port of Alaska Modernization Program*

Structure	Design Classification	Seismic Hazard Level	Seismic Performance Level
New T2 platform and approach trestles	Seismic Berth	OLE	Minimal damage
	Seismic Berth	CLE	Minimal damage <sup>a</sup>
	Seismic Berth	DE	Controlled and repairable damage <sup>b</sup>

Notes:

DE level is equivalent to two-thirds of MCE in accordance with ASCE 7-10. Ground motions from ASCE 7-10 exceed those from ASCE 7-05, *Minimum Design Loads for Buildings and Other Structures*, specified in ASCE/COPRI 61-14.

<sup>a</sup> Seismic performance level exceeds that required by ASCE/COPRI 61-14

<sup>b</sup> Controlled and repairable damage defined as being operable within 7 days.

### 3.2.11 Vessel Fendering System

The new fender system will eliminate the pin piles and support the fender panels by hanging them from face of the structure. This is a similar design to that used at Nikiski. The fender panels will be faced with ultra-high molecular weight (UHMW) material and connected by rubber fenders at the top and bottom of the steel fender panel.

# Rail-mounted, Container-handling Gantry Crane

Rail-mounted, container-handling gantry cranes (container cranes) will be used at T1 to handle loading and unloading of containers from ships. The design criteria for container cranes are described in this section. The container cranes will be procured by the preferential user of T1 (Matson). It is the DOR's responsibility to verify that the design of T1 is compatible with the container crane that is ultimately procured.

## 4.1 Codes, Standards, and References

- American Society of Civil Engineers (ASCE) 7-10, Minimum Design Loads for Buildings and Other Structures
- ASCE/Coastal, Oceans, Ports, and Rivers Institute (COPRI) 61-14, Seismic Design of Piers and Wharves

## 4.2 Design Criteria

Tables 4-1 and 4-2 summarize the design criteria for container cranes. For a detailed discussion of container crane design criteria and design loads, please refer to the Crane Load Estimates Port of Anchorage Terminals 1 and 2 (Liftech, 2016).

**Table 4-1. Geometry Criteria**

*Port of Alaska Modernization Program*

Item	Dimension
Rail gage	100 ft
Face of fender to waterside rail (maximum)	18 ft
Outreach from waterside rail	164 ft
Backreach from landside rail	49 ft, 2 inches
Lift height above gantry rails	114 ft, 10 inches
Clearance between the legs	60 ft
Clearance under the portal tie	50 ft
Out-to-out bumpers	88 ft, 7 inches
Main equalizer spacing, 8 wheels per corner	46 ft, 11 inches
Wheel spacing	4 ft, 11 inches (preliminary)
Tie-down spacing	69 ft, 2 inches
Stability stool spacing	67 ft (preliminary)
Boom stowage angle	87°
Aircraft clearance height	347 ft, 9 inches

° = degree

ft = foot

**Table 4-2. Weight and Load Criteria***Port of Alaska Modernization Program*

Item	Data
Crane weight include ballast, excluding trolley	3,000 kips (1,360 tonnes)
Crane weight tributary to wharf (per ASCE/COPRI 61-14)	1,440 kips (653 tonnes)
Rated load under spreader	65 LT (66 tonnes)
Rated load under cargo beam	75 LT (76 tonnes)
Trolley weight	71.7 kips (32.5 tonnes)
Lift system weight	43 kips (19.5 tonnes)
Cargo beam lift system	7.7 kips (3.5 tonnes)
Operating wind basis	55 mph (24.6 m/s) 70 mph for gantry to tie-down
Stowed wind basis for crane wheel loads (per ASCE 7-10)	130 mph basic wind speed
Seismic criteria (per ASCE/COPRI 61-14)	The smallest load calculated using a spectral analysis, a time history analysis, or the lateral load required to tip the crane onto the landside rail, the waterside rail, or two main equalizer pins

LT = long ton

m/s = meter per second

mph = mile per hour

# Electrical System

The electrical system shall be designed in accordance with the codes and standards described in this section. These standards shall be confirmed and supplemented as necessary by the DOR during the design process and shall be incorporated into the contract documents.

## 5.1 Codes, Standards, and References

The following are representative of the codes and standards that shall be incorporated into the contract documents as applicable:

- International Building Code
- International Fire Code
- International Energy Conservation Code
- NFPA 70, National Electrical Code
- NFPA 70E, Standard for Electrical Safety in the Workplace
- NFPA 72, National Fire Alarm Code
- Illuminating Engineering Society of North America (IESNA) Handbook
- Building Industry Consulting Service International (BICSI), Telecommunications Distributions Methods Manual
- Institute of Electrical and Electronics Engineers (IEEE), National Electrical Safety Code
- Telecommunications Industry Association/Electronic Industries Alliance 568, Commercial Building Telecommunications Cable Standard
- Anchorage Municipal Light and Power (ML&P) Electrical Service Requirements
- General Communications Inc. (GCI) Cable Installation Practices for Commercial/Military Facilities
- Alaska Communications System (ACS) Installation Practices for Commercial/ Military Facilities
- MASS

## 5.2 Design Criteria

### 5.2.1 General Power Requirements

POA electrical systems will meet the following design guidelines:

- Underground conduit will be Schedule 40 high-density polyethylene (HDPE) polyvinyl chloride (PVC) unless otherwise noted.
- Conduits will be buried a minimum of 36 inches below grade and will be bedded in accordance with MASS specification requirements.
- Galvanized rigid steel conduit will be used in all aboveground applications. Rigid steel conduit will be PVC coated for use in utilidor and exposed locations.

- Vaults and in-ground junction boxes will be aircraft rated in all locations subject to vehicle traffic. Additionally:
  - Vaults guarded by bollards or other approved means can have standard pedestrian ratings.
  - Vaults will be of concrete construction except for vaults in protected areas, which can be fiberglass polymer style.
- Medium voltage cables: Ethylene Propylene rubber (EPR), high-heat-resistant (105 degrees C), water-resistant, suitable for direct burial, sunlight resistant, 133 percent rated insulated, 25 percent overlapping copper shield, stranded copper wire.
- Low voltage conductors/cables: Cross-linked polyethylene (XLPE), high-heat-resistant, water-resistant (XHHW-2) insulated copper wire.
- Three conductor cables will be used in underground construction for conductors of size 310 or smaller per MASS requirements.
- Conductors will be sized for loads served and upgraded as necessary to keep a maximum voltage drop of 5 percent to the equipment connections.
- Aboveground enclosures, switch boards, and other electrical components will be, as a minimum, National Electrical Manufacturers Association (NEMA) 3R stainless steel. Wiring will be NEMA 6, and be suitable for occasional submersion.
- High-mast light towers will be constructed with galvanized steel.
- Light fixtures will be of corrosion-resistant construction.
- Downlights will be full cut-off, and floodlights will have visors so that no direct light illuminates higher than a 90-degree plane.

### 5.2.2 Area Lighting

Area lighting will be designed to meet the following requirements:

- POA area lighting shall be LED
- Lighting along the dock face will be designed to an average of 5 foot-candles.
- Poles will be located to allow free access along the dock, and to avoid horizontal and vertical conflict with the cranes. Locations shall be coordinated with the preferential user of the terminal.
- High-mast poles will be glare-reducing industrial floodlights.
- Floodlights will be provided with shielding to eliminate any light directed higher than a 60-degree plane.
- Lighting for general yards will be designed to an average of 3 foot-candles and will be glare-reducing industrial floodlights.
- In addition to high-mast lighting, additional lower-level security lighting will be provided on new buildings and other equipment that may cause shadowing or otherwise cause dark areas.